

Intermittent Tray Denester

FEATURES AND BENEFITS

- This denester is unique in that it allows for horizontal presentation
- Standard construction incorporates a sanitary design suitable for most bakery or pharmaceutical installations. Washdown construction available for wet environment and food applications
- Standard air cylinder drive offers a virtually maintenance free motion control and drive system
- Quick and easy product changeover means less downtime and greater machine efficiency
- Many options available, allowing the end user to customize the machine to their specific needs
- Materials typically handled include; plastic plates, plastic trays, styrofoam trays, foil trays, paperboard trays, and lids

Intermittent Tray Denester

Typical Utility Requirements

- ELECTRICAL: 115 VAC 10 Amps Max (with pump)
- AIR: 80 PSI filter and regulator provided
- VACUUM: Up to 10 SCFM At 20" HG

Maximum Speeds

- 40 cycles per minute horizontal placement mode

Product Size Range

- Height: 6, 9, 12, and 15" high magazines are available
- Width: 18" and 28" wide magazines are available

The maximum product size is determined by the magazine centers.

Options Available

- Screw height adjustment
- 18" or 28" wide machine
- Floor stand
- Polycarbonite front guard
- 30, or 48" long magazine
- No tool magazine changeover
- Quick change magazine
- Kwik Klip™ assemblies
- Venturi vacuum system
- Photoelectric cycle control
- Missed detection system with or without buzzer
- Casters

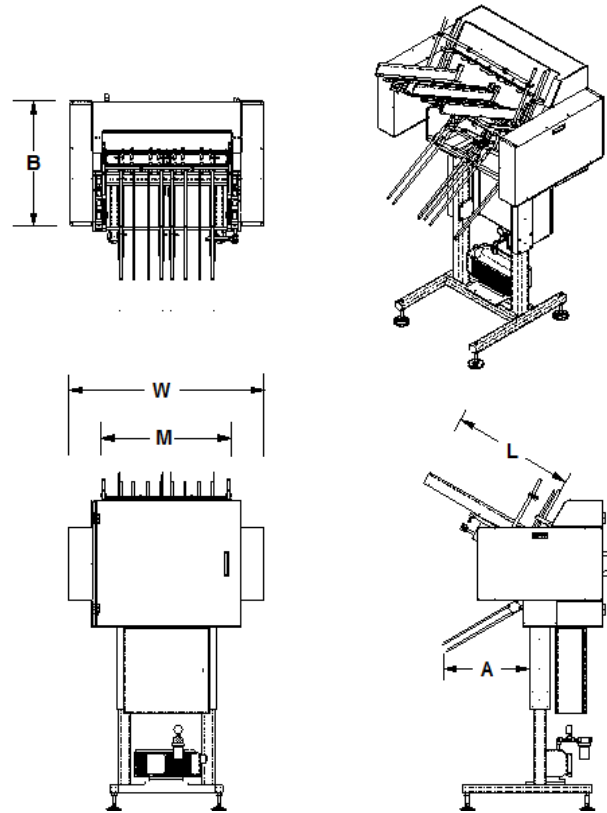

BASIC UNIT

MODEL	A	B
100	20"	29.15"
200	20"	29.15"

MAGAZINE

WIDTH (W)		LENGTH (L)
M	W	L
18"	33.50"	16.25"
		30"
28"	43.50"	48"

MGS

9900 85th Ave North, Maple Grove, MN 55369 USA

T (800) 790-0627

www.mgsmachine.com

info@mgsmachine.com

