

Bulk Feeder

FEATURES AND BENEFITS

- Singulates and orients bulk cylindrical products for downstream operations
- Integrated bulk product hopper provides buffer and product metering into singulation system
- Clear polycarbonate upper guarding and stainless steel lower guarding
- Stainless steel product fall through pans
- Gentle product handling that minimizes product recirculation
- Standard construction incorporates a design suitable for most pharmaceutical, food and industrial solutions
- Solid frame construction and quiet, energy efficient drive system provides years of high performance with low noise
- Many options available, allowing the end user to customize the feeder to their specific needs

Bulk Feeder

Standard Machine Features

- CRS welded painted frame
- Push button controls
- VFD drive motors

Typical Utility Requirements

- ELECTRICAL: 115 VAC, 20 Amps Max, variable speed DC drives
- AIR: 80 PSI (when required) filler and regulator provided

Speed Range

- Typical range is 30 – 300 PPM (depending on part characteristics)

Options Available

- Elevating bulk product prefeeder
- Part detection and orientation vision systems
- Multiple part tooling
- Discharge conveyors
- Gravity tracks
- Powered orienting gravity rollers
- High level inhibit system
- Escapements, shuttles, pick and place, and other custom downstream product handling
- Touchscreen HMI

Types of Products Run

- Ammunition
- Cosmetics
- Tubes
- Dosage spoons
- Syringes
- Vials
- Other cylindrical products

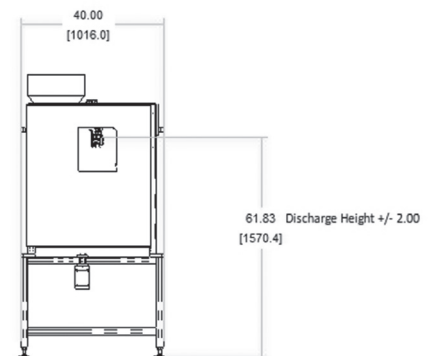
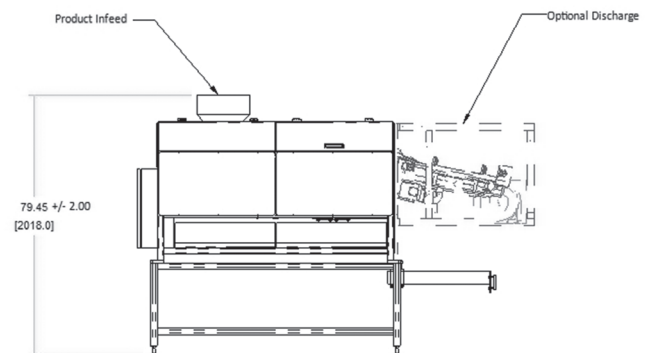
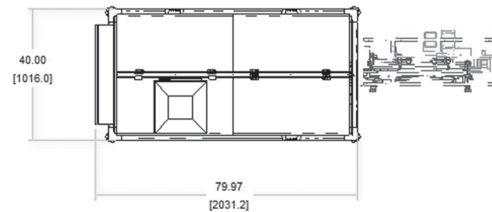

MGS

9900 85th Ave North, Maple Grove, MN 55369 USA

T (800) 790-0627

www.mgsmachine.com

info@mgsmachine.com

